

QUV Operator Training

Bill Tobin – Senior Technical Marketing Specialist

Andy Francis – Marketing Director

Sean Fowler – Senior Technical Director

Dave Duecker - Senior Technical Marketing Specialist

Q-Lab

[View Recorded Presentation](#)



Q-Lab's Operator Training Series

Today is the first of a three-part webinar series on basic operation of our weathering and corrosion testers

All upcoming and archived webinars can be accessed at:
q-lab.com/webinars

Date	Topic
06 Oct	QUV
13 Oct	Q-SUN
20 Oct	Q-FOG

Administrative Notes

You'll receive a follow-up email from info@email.q-lab.com with links to a survey, registration for future webinars, and to download the slides

Use the Q&A feature in Zoom to ask us questions today!



Topics

- Safety
- Functions of the Tester
- Running a Test
- Calibration
- Maintenance

Electrical Shock

- The QUV uses 400V to operate the lamps
- Due to this high voltage, the QUV uses interlock switches to remove power to the lamps when the end covers are removed.
- Always use caution around high voltage, and do not bypass the safety interlock switches!



UV Exposure

- One sample holder removed
- Hand 5 cm (2 in) from lamps (same distance as specimens)
 - Allowable Daily Exposure: 1 minute
- Hand 30 cm from lamps
 - Allowable Daily Exposure: 6 minutes
- Face 1.0 m from lamps
 - Allowable Daily Exposure: 18 minutes

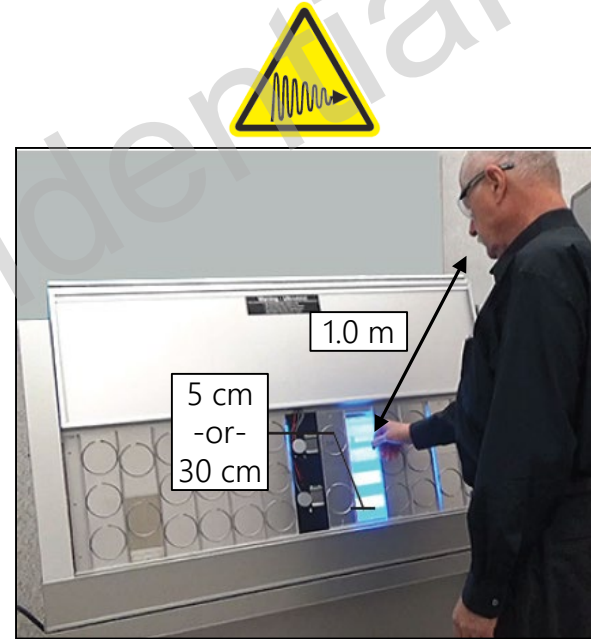

UV Exposure

- All sample holders removed
- Hand 30 cm from lamps
 - Allowable Daily Exposure: 2 minutes
- Face 1.0 m from lamps
 - Allowable Daily Exposure: 6 minutes

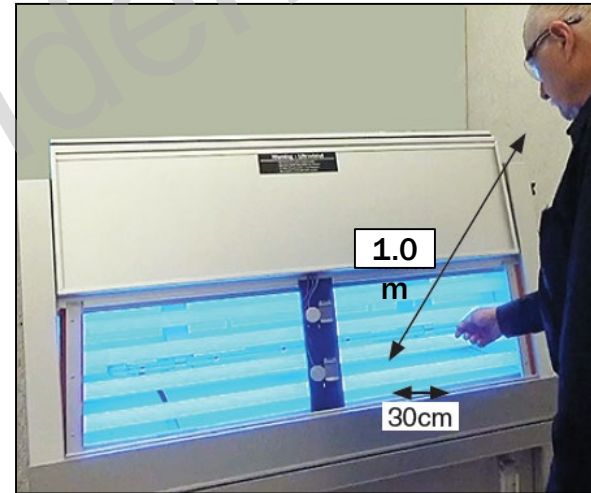

QUV Door Interlocks

- The UV dosage someone will see from periodic irradiance calibration and specimen handling is equivalent to being outside on a clear day
- Nevertheless, QUV's come standard with interlocks on the front and rear swing doors that will shut off the lamps after 30 seconds.



Topics

- Safety
- **Functions of the Tester**
- Running a Test
- Calibration
- Maintenance

QUV Functions

- UV Light System
- Controlled Temperature
- Condensation
- Water Spray (optional)

QUV Overview

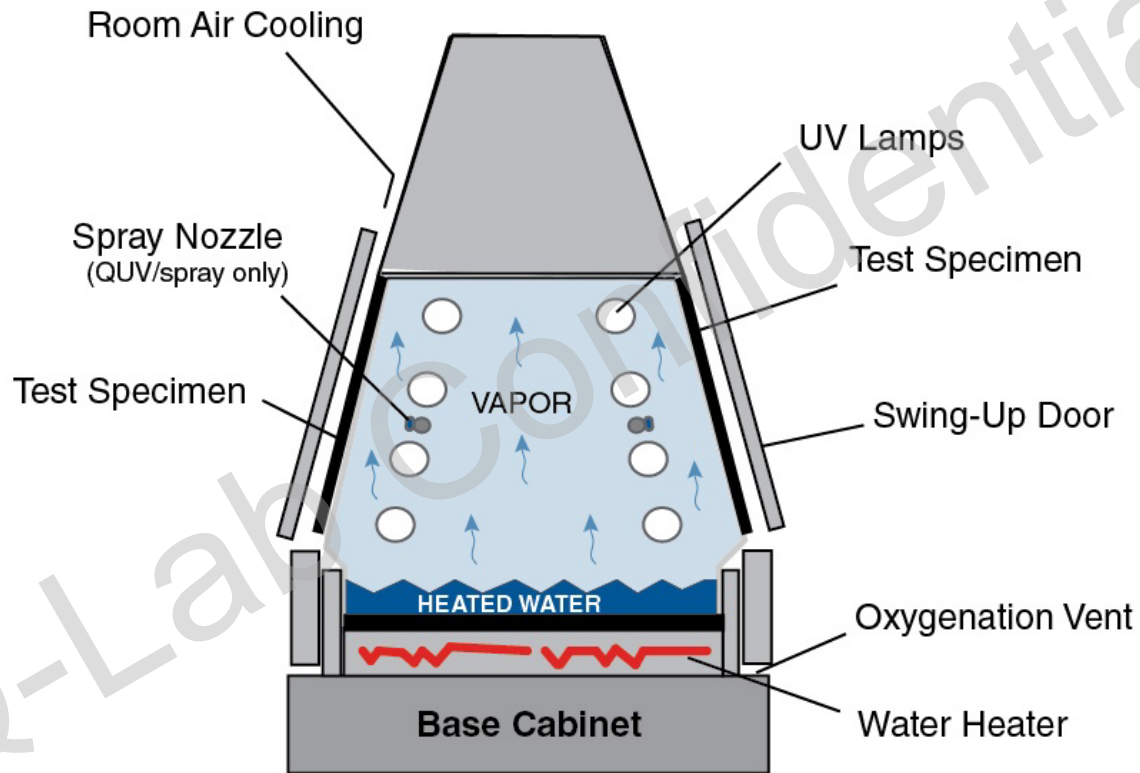

UV Light System

- QUV/basic
 - No control of irradiance
 - 4 separate ballasts
- QUV/se, QUV/spray, QUV/cw, QUV/uvc
 - Solar Eye Irradiance Control maintains the same irradiance at all times
 - Single ballast controls 4 banks of lamps

QUV/basic UV Light System

- 4 Pairs of lamps
- 4 ballasts
- Lamps are on or off
- Fixed amount of power
- As lamps age, UV output decreases

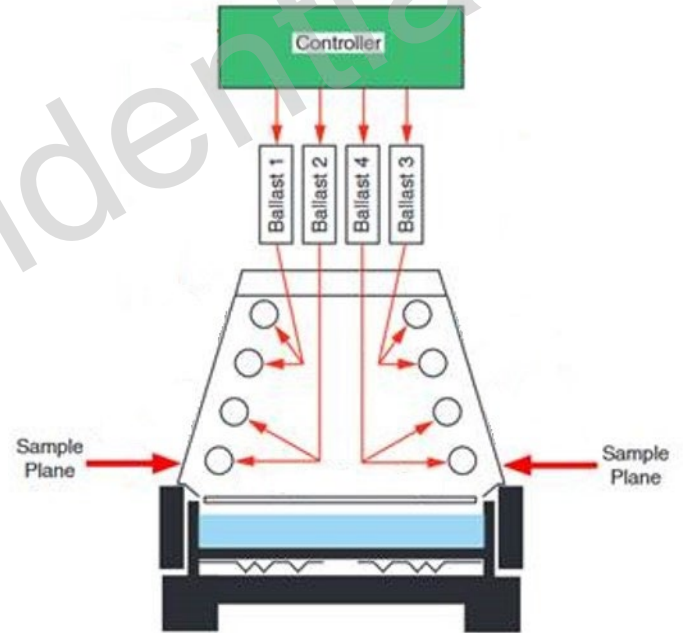

QUV/basic Lamp Rotation Sequence

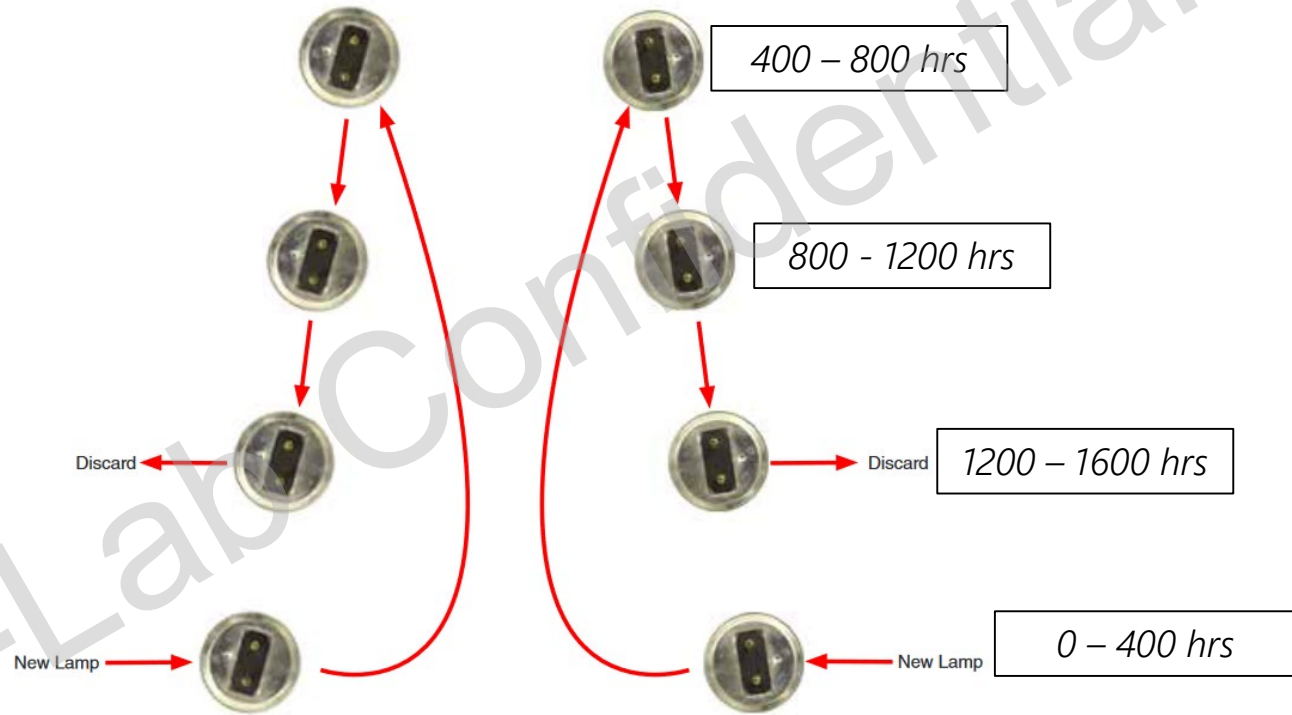

QUV/basic UV Lamp Aging

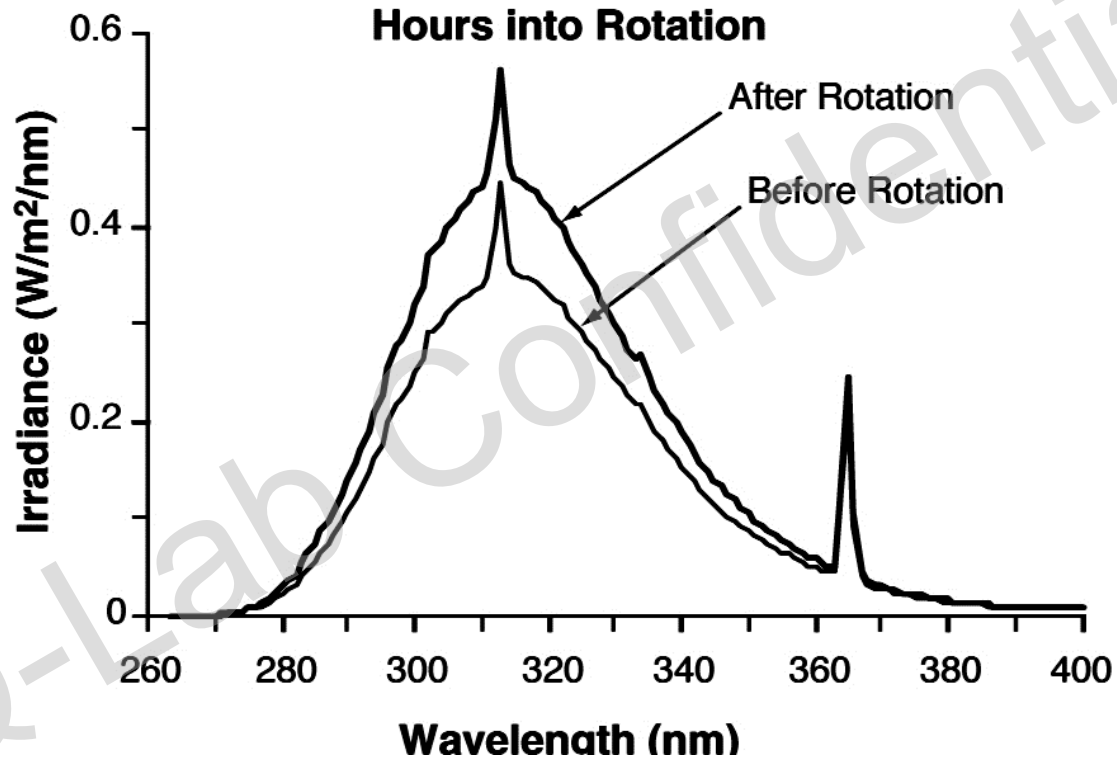

QUV/basic Limitations

- Lamp-to-lamp and lot-to-lot variability
- Inconsistent lamp maintenance
- Variability in ballast cooling blower and ballast
- Higher consumable cost due to frequent replacement of lamps

Solar Eye Irradiance Control

- One specialized ballast powers four channels of eight total lamps
- Power to lamps controlled to maintain constant UV irradiance
- Benefits are numerous –
 - Calibrated light source for better repeatability
 - Controlled Higher & Lower Intensity
 - Replace lamps only when needed

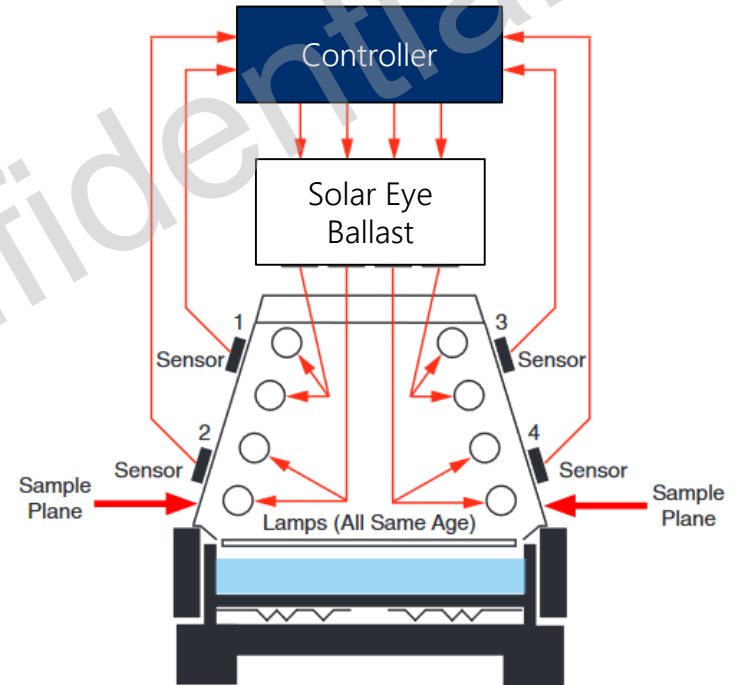

Typical Irradiance

	UVA-340	UVA-340+	UVB-313EL	UVB-313EL+	QFS-40	UVC-254
QUV/basic Typical Irradiance	0.89	Not Recommended	0.71	Not Recommended	0.48	Not Available
QUV with SOLAR EYE Minimum Irradiance	0.20	0.35	0.20	0.20	Not Recommended	1.0
QUV with SOLAR EYE Typical Irradiance	0.68-0.89	0.76-0.95	0.48-0.62	0.48-0.71	Not Recommended	2.0-6.0
QUV with SOLAR EYE Maximum Irradiance	1.55	1.85	1.23	1.85	Not Recommended	13.0

Note: Irradiance value ($W/m^2/nm$) at 340 nm for UVA lamps, 310 nm for UVB/QFS lamps
Irradiance in mW/cm^2 @254 nm for UVC lamps ($10 \times W/m^2$)

UVA-340 / UVA-340+ Lamps SPD

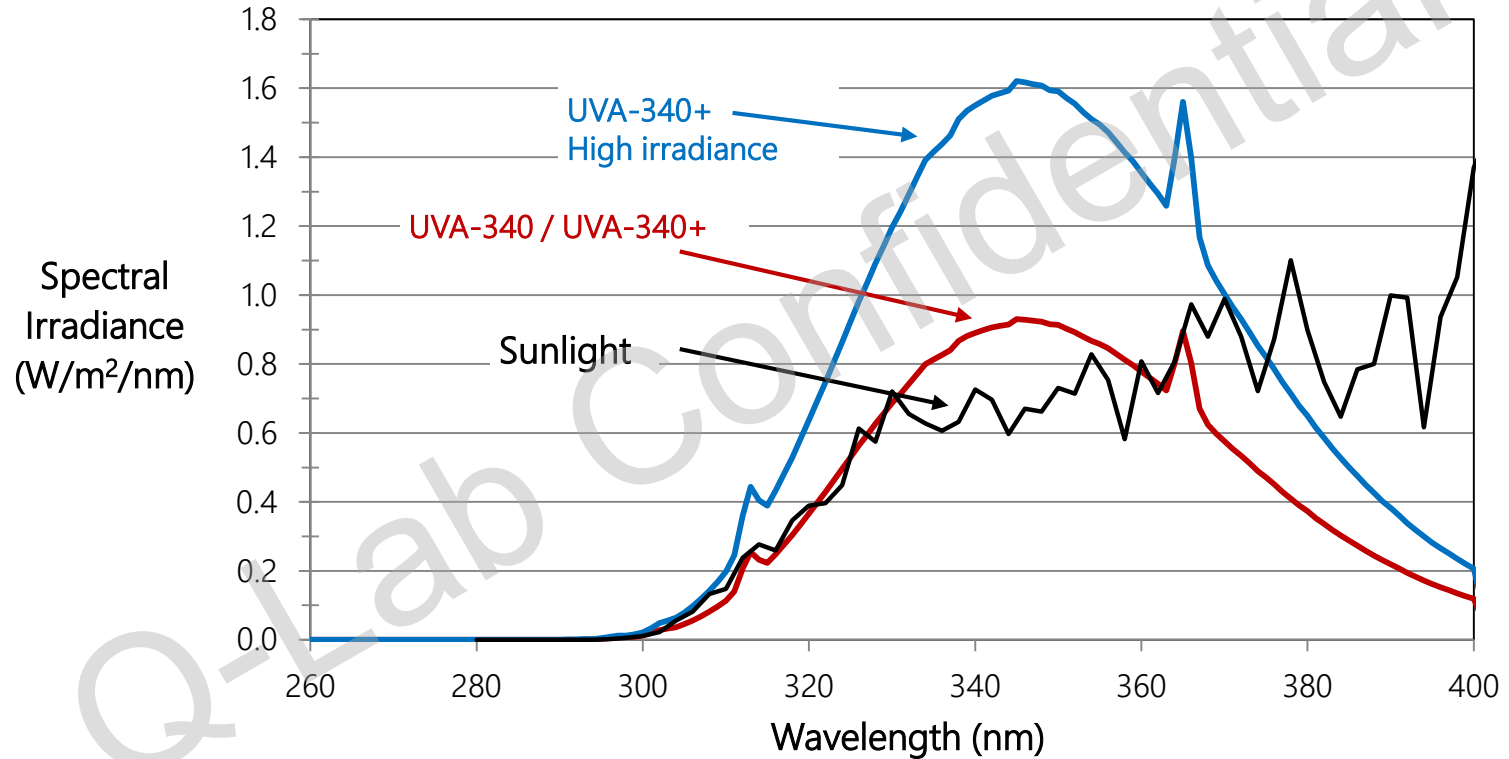

UVA-351 Lamps SPD

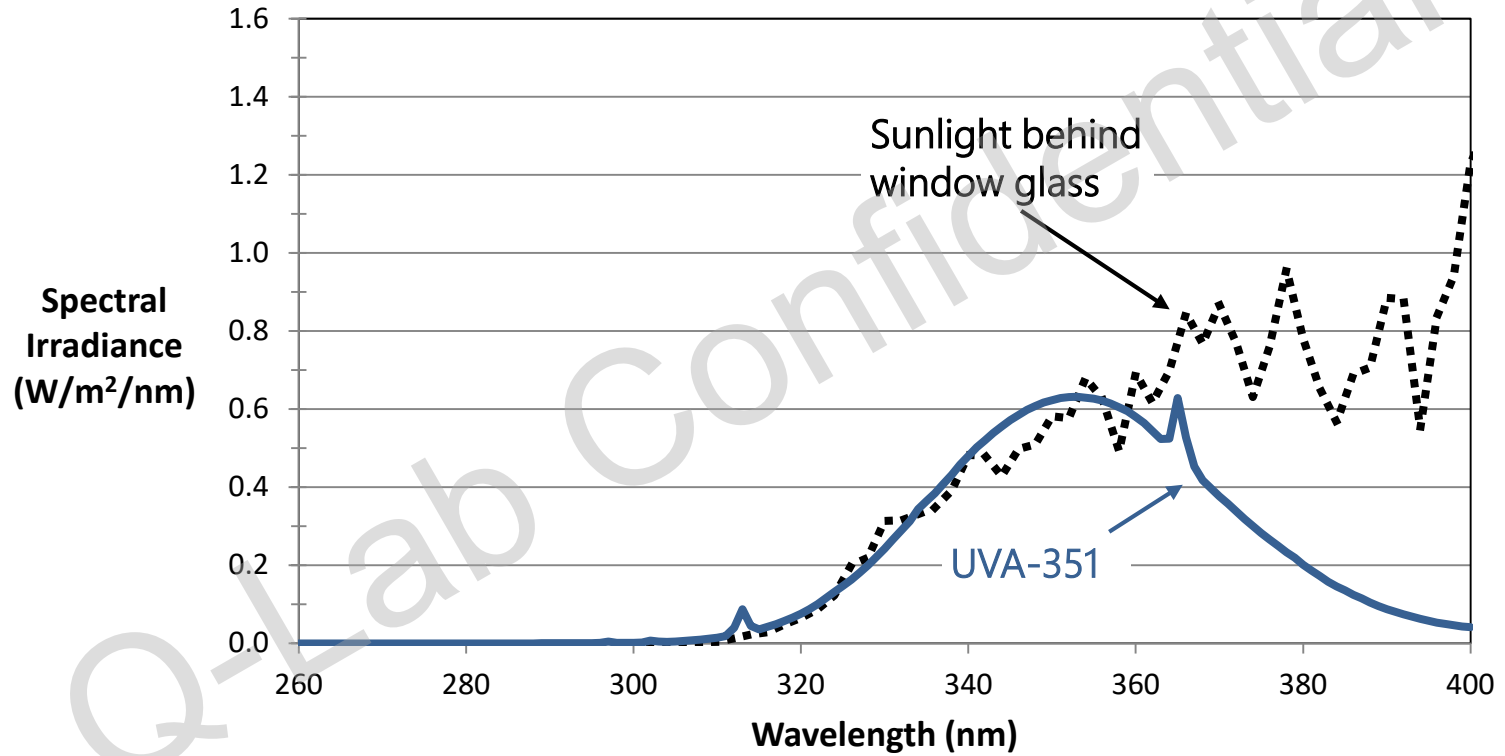

UVB Lamps SPD

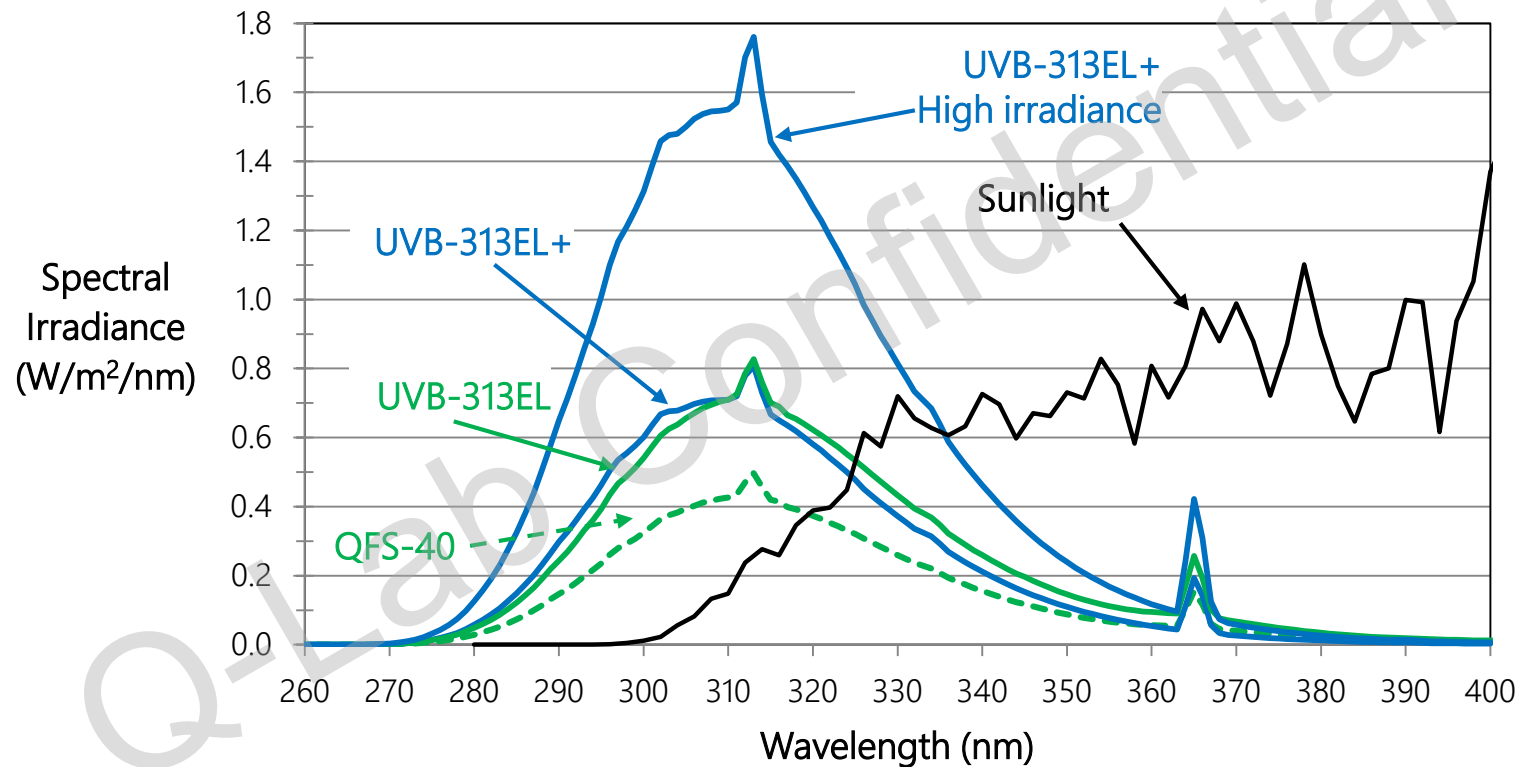

Cool White SPD

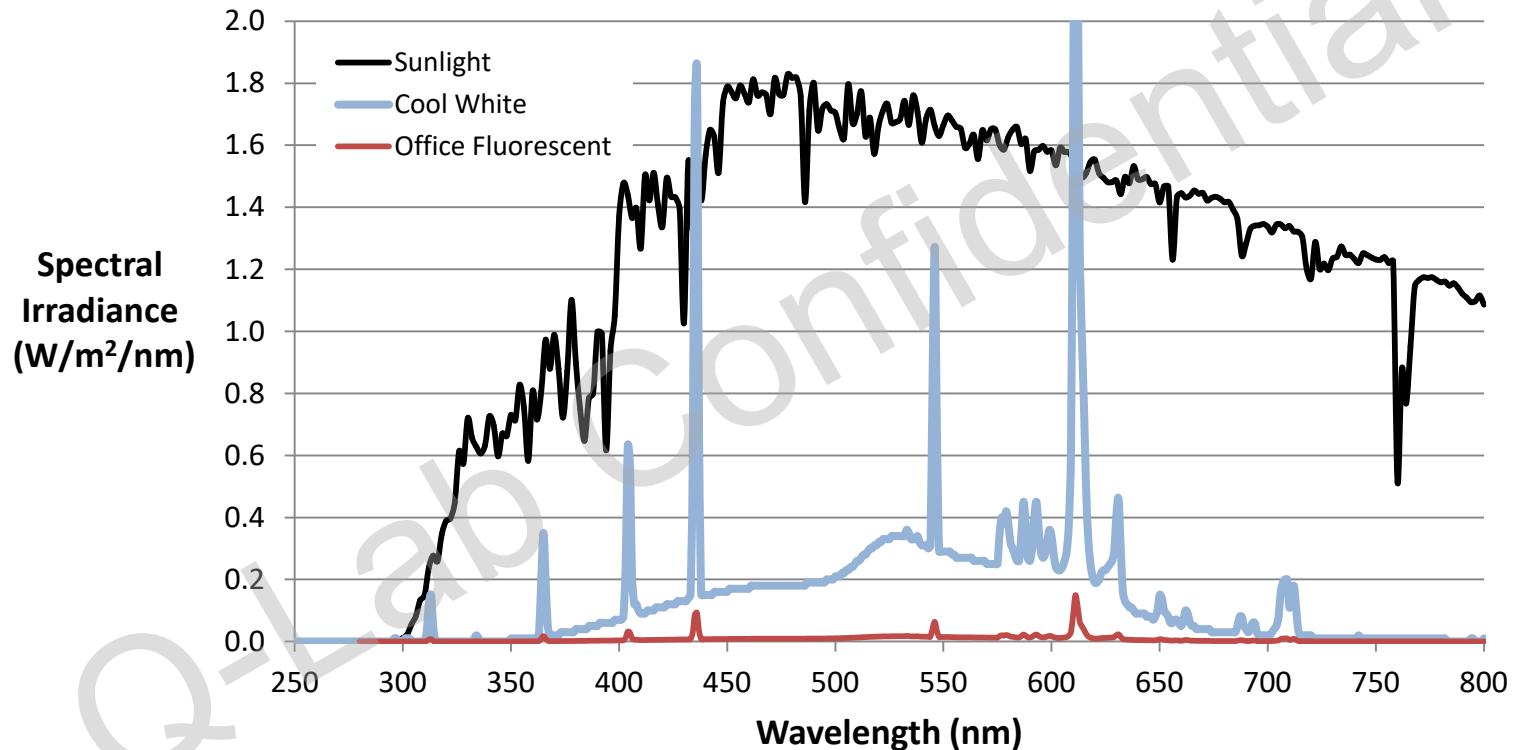

UVC Lamps

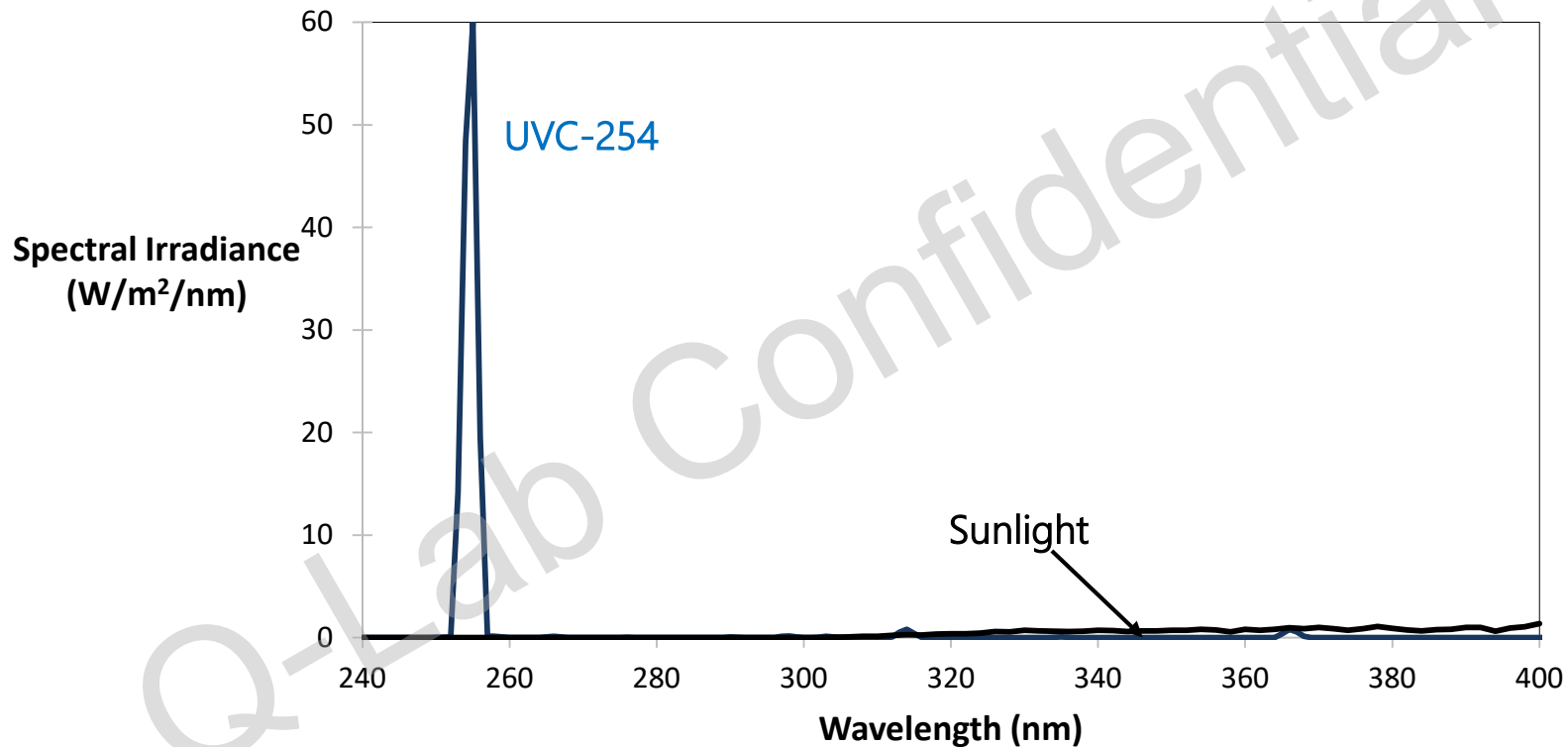

Solar Eye Lamp Aging

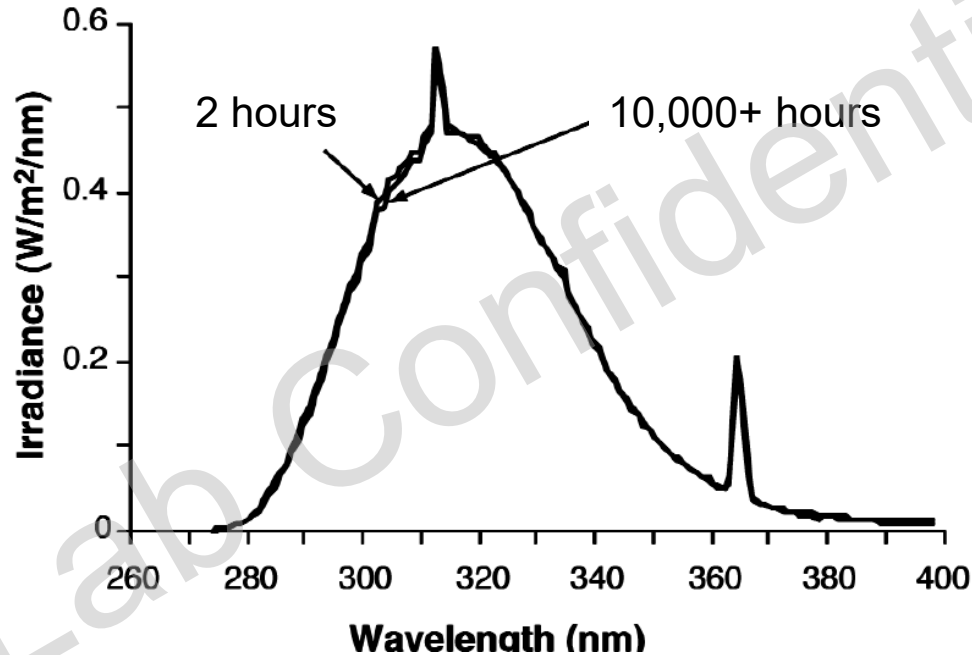

Minimal to no spectral change after 10,000 hours in SOLAR EYE models.

Temperature Control in UV Function

- Controlled by panel temperature sensor
 - Uninsulated
 - Insulated
- Blower
- Air Heater
- Both Blower and Air Heater are on during UV Cycle

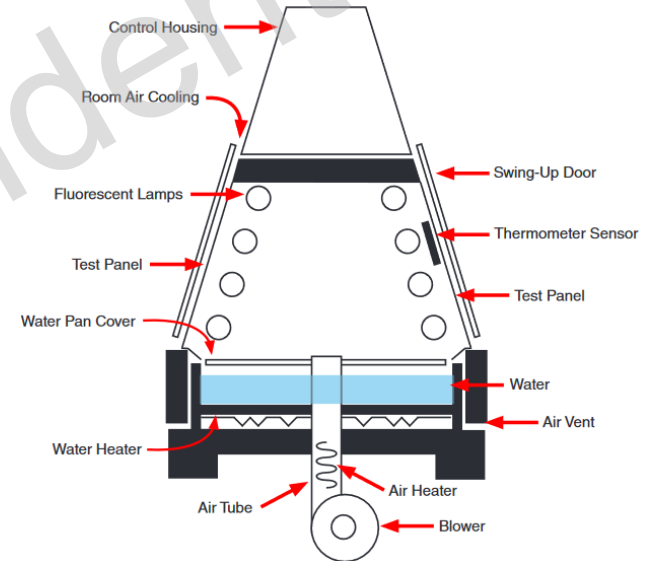

QUV Moisture

- Condensing Humidity
 - Hot condensation
 - Maximum water uptake
- Water Spray
 - Thermal Shock
 - Erosion

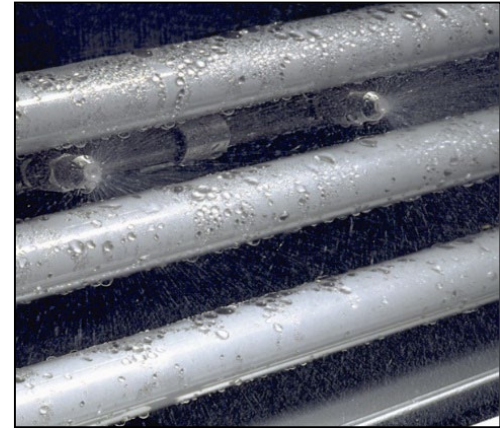

QUV Condensation

- Standard in most QUV's
- Requires tap water connection, but distilled water reduces maintenance, do not soften water.
- Uses approximately 8 liters/day
- Water Heater is on, warming the water and filling the chamber with warm water vapor
- Water Temperature Sensor ensures safety and that the water pan is full
- Blower is on until the panel temperature is met
- Lamps and Air Heater are off

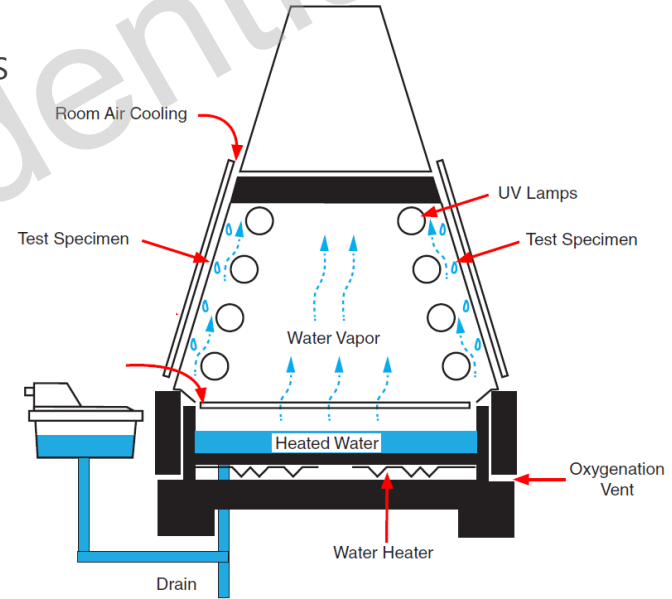

QUV/spray and QUV/spray-RP

- Purified water required ($> 200 \text{ k}\Omega$ resistivity)
- 12× nozzles total, 6× on each side
- 7 liters/minute
- Panel temperature is displayed but not controlled
- Lamps, Water Heater, Air Heater, and Blower are off
- QUV/spray-RP is an optional system that recirculates and re-purifies water (purified water connection still required)

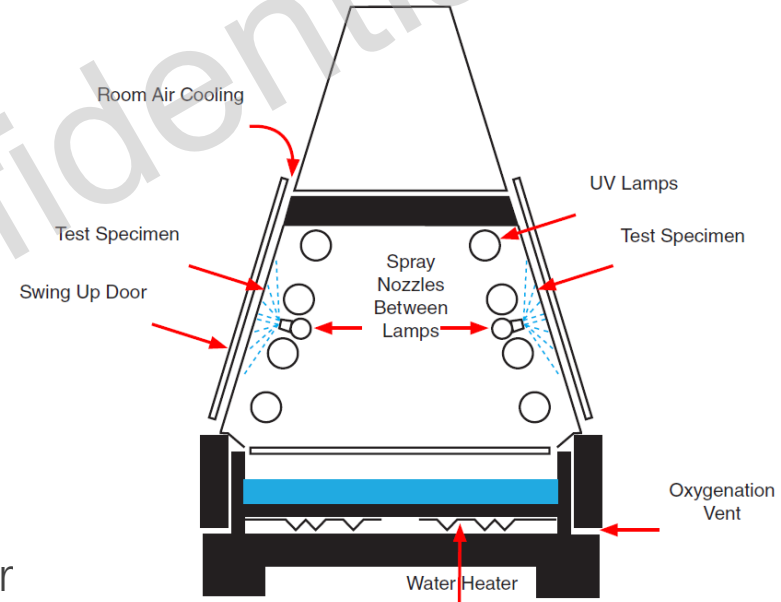

Topics

- Safety
- Functions of the Tester
- **Running a Test**
- Calibration
- Maintenance

Step 1: Select the Lamps

- UVA Lamps
 - UVA-340, UVA-340+
 - UVA-351
- UVB Lamps
 - UVB-313EL, UVB-313EL+
 - QFS-40
- UVC Lamps
 - UVC-254
- Cool White Lamps (V-60183)



DO NOT MIX LAMP TYPES!

Step 2: Program the Tester

- Enter the test cycle or select from set of pre-programmed cycles¹
 - Function (UV, CONDENSATION, DARK, DARK+SPRAY, UV+CONDENSATION², UV+SPRAY²)
 - Irradiance (for SOLAR EYE equipped models only)
 - Temperature
 - Cycle Time
- Set the test duration in hours

1. The QUV includes up to 12 commonly used test cycles (depending on model)

2. UV+CONDENSATION and UV+SPRAY are not enabled in default programming

QUV Front Control Panel



QUV Display

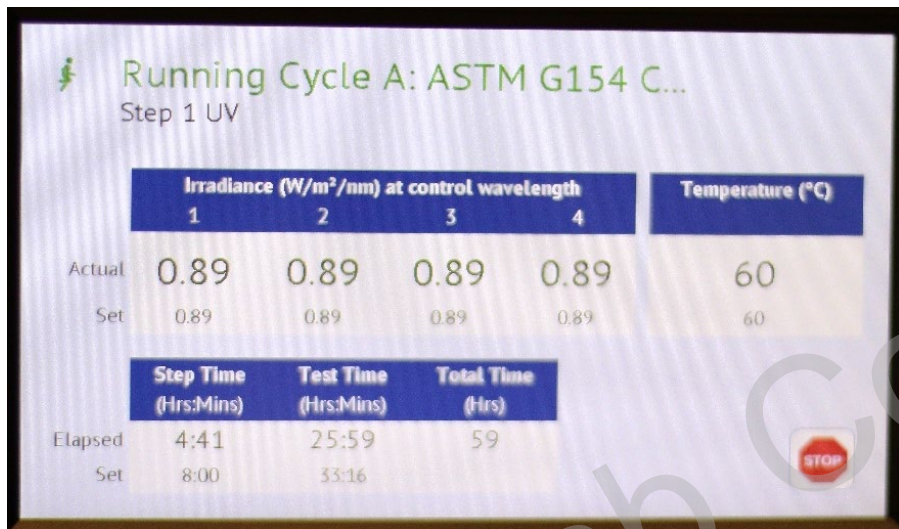

Running Cycle A: ASTM G154 C...
Step 1 UV

	Irradiance (W/m ² /nm) at control wavelength				Temperature (°C)
	1	2	3	4	
Actual	0.89	0.89	0.89	0.89	60
Set	0.89	0.89	0.89	0.89	60

	Step Time	Test Time	Total Time
	(Hrs:Mins)	(Hrs:Mins)	(Hrs)
Elapsed	4:41	25:59	59
Set	8:00	33:16	

STOP

Status screen
Setpoint and actual controls
Test timers

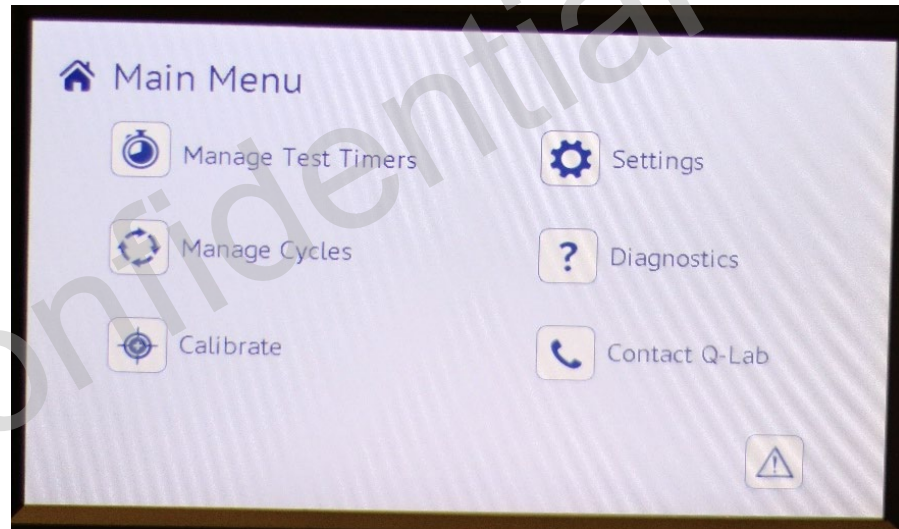

Menu screen
Cycle management
Calibration
Settings

QUV Display

 **Running Cycle A: ASTM G154 C...**
Step 1 UV

	Irradiance ($W/m^2 /nm$) at control wavelength				Temperature ($^{\circ}C$)
	1	2	3	4	
Actual	0.89	0.89	0.89	0.89	59
Set	0.89	0.89	0.89	0.89	60





	Step Time (Hrs:Mins)	Test Time (Hrs:Mins)	Total Time (Hrs)
	Elapsed	4:43	16:43
Set	8:00	168:00	



Status screen

Setpoint and actual controls
Test timers

 **Main Menu**

-  Manage Test Timers
-  Settings
-  Manage Cycles
-  Diagnostics
-  Calibrate
-  Contact Q-Lab



Menu screen

Cycle management
Calibration
Settings

QUV Menu Screen

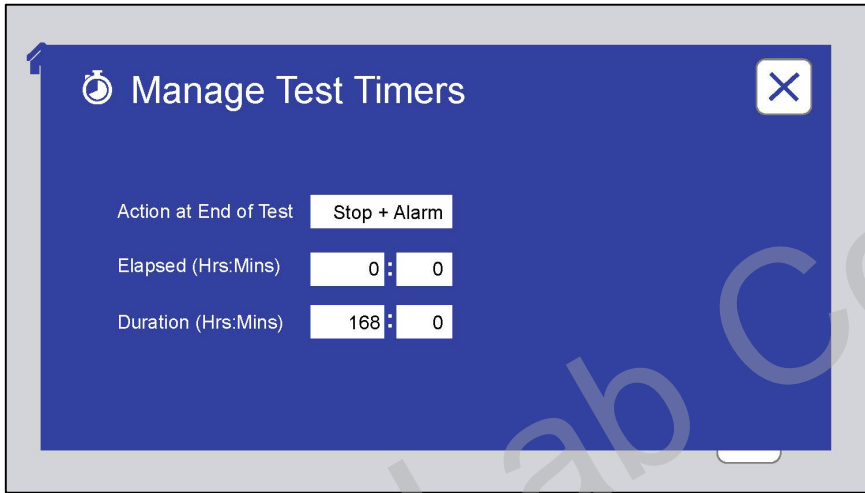

Test Duration

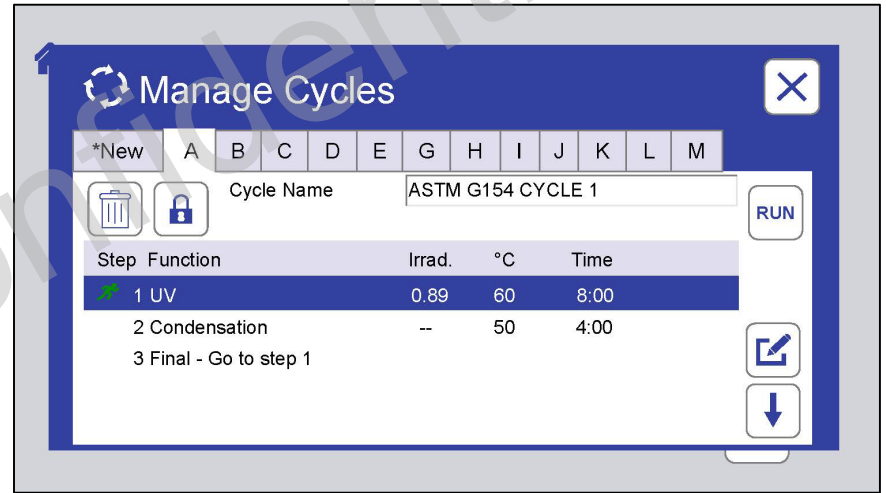

Managing Cycles

Step 3: Calibration

- More on this later!

Q-Lab Confidential

Step 4: Mount Specimens

- The QUV must be completely sealed
 - All holders filled with specimens or blanks
 - End seals in place
 - Gaps may prevent condensation and unattainable temperature conditions and will affect uniformity
- Insulated or three-dimensional specimens may be hotter than the black panel
 - Leaving the door open will increase specimen temperature



QUV End Seals

3-Dimensional Specimens

Specimens should not extend past the plane of the specimen holder into the chamber

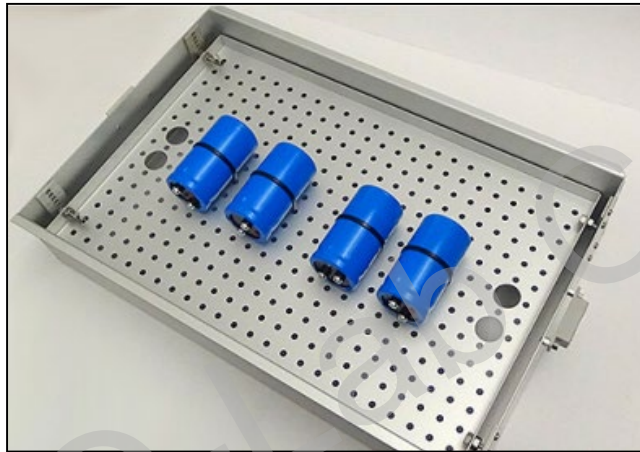

Adjustable Quadrant Box



Lumber Holder

QUV Insulated Black Panel

For 3D quadrant boxes and thick plastic specimens, a black panel with insulation may provide better representation of specimen temperatures.

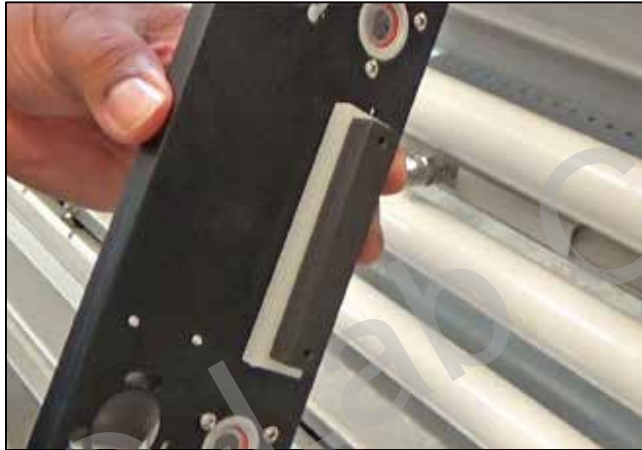

QUV Insulated Black Panel



QUV with door removed and 3D Boxes

Step 5: Running a Test



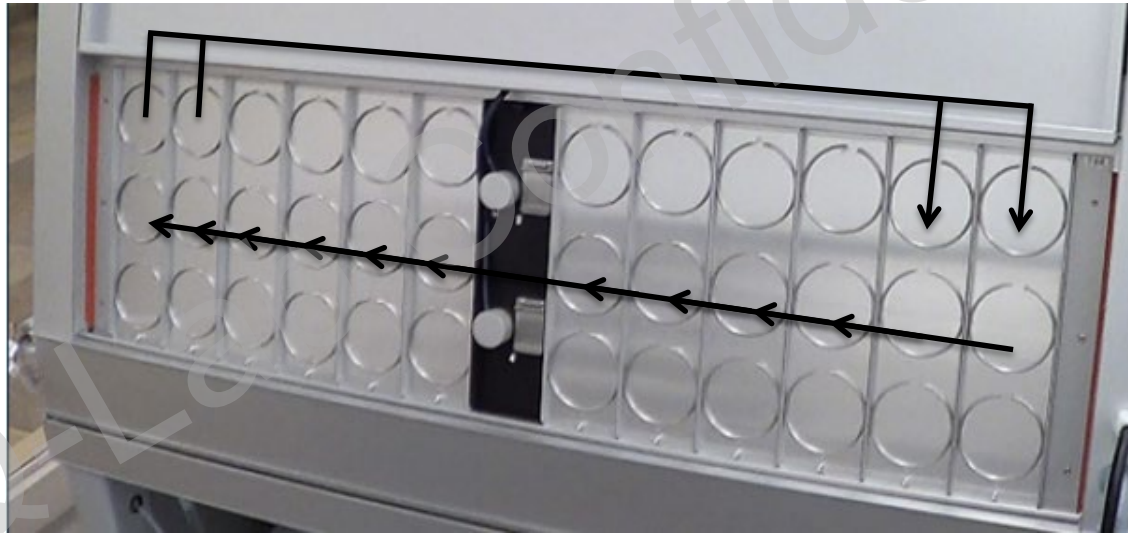

- Specimen Reposition
- Lamp Rotation (QUV/basic)
- Calibration
 - Irradiance every 500 hrs for SOLAR EYE models
 - Temperature every 6 months
- Tester Operation
- Data Logging via VIRTUAL STRIPCHART (if configured)

Specimen Repositioning

- Ensures best repeatability and reproducibility
- Perform at least 4 times per test

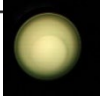

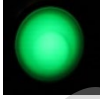
LED Status Indicator

Color		Appearance	Meaning
Red		<i>Flashing</i>	Error, test stopped
Yellow		<i>Flashing</i>	Notification, test still running
White		Static	Power on, stopped, no active error
Green		Static	Test running, no active error
Blue		<i>Flashing</i>	Test completed
Magenta		<i>Flashing</i>	Software install or VSC transfer

Topics

- Safety
- Functions of the Tester
- Running a Test
- **Calibration**
- Maintenance

Irradiance Calibration

- For SOLAR EYE models only
- Calibration every 500 light hours
- QUV flashes a reminder when calibration is due
- Requires
 - UC10 Smart Sensor (UC10/UV, UC10/CW, UC10/UVC)
 - UC1 handheld display (adaptor for older models)

Irradiance Calibration

Maintaining CR10 & UC10

- Calibration is valid for 1 year
- When not in use, sensor should be stored in supplied package
- Calibration sensor should never be left in the calibration port on the tester
- Prior to calibration, clean sensor window with alcohol and a soft cloth



Irradiance Calibration

Smart Sensor Info

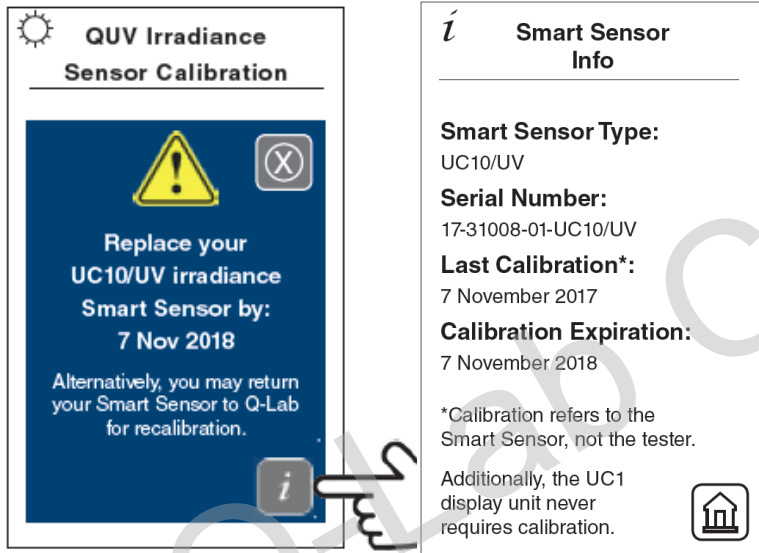

The handheld display shows a warning message: "Replace your UC10/UV irradiance Smart Sensor by: 7 Nov 2018. Alternatively, you may return your Smart Sensor to Q-Lab for recalibration." A hand icon points to an information icon (i) at the bottom right of the warning box. To the right, a "Smart Sensor Info" window is open, displaying the following details:

Smart Sensor Type:	UC10/UV
Serial Number:	17-31008-01-UC10/UV
Last Calibration*:	7 November 2017
Calibration Expiration:	7 November 2018
*Calibration refers to the Smart Sensor, not the tester.	
Additionally, the UC1 display unit never requires calibration.	

UC1 Handheld Display

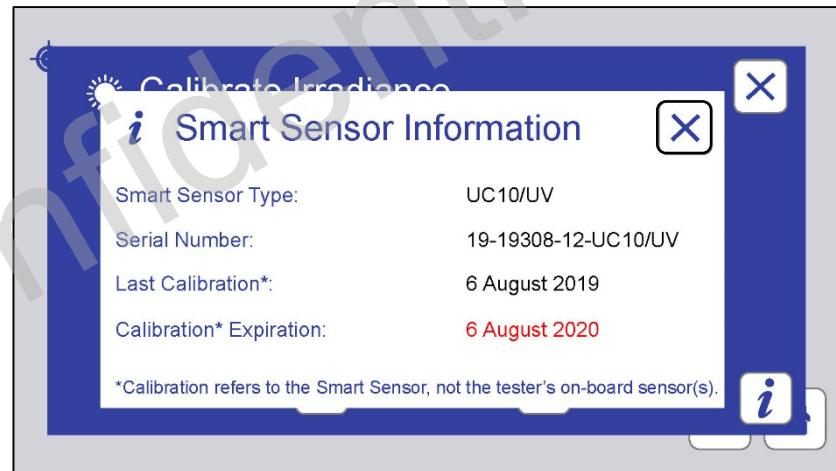

The touchscreen display shows a "Smart Sensor Information" window with the following details:

Smart Sensor Type:	UC10/UV
Serial Number:	19-19308-12-UC10/UV
Last Calibration*:	6 August 2019
Calibration* Expiration:	6 August 2020

*Calibration refers to the Smart Sensor, not the tester's on-board sensor(s).

QUV Touchscreen Display

Irradiance Calibration

- Select lamp type
- Place UC10 in tester, wait for irradiance to stabilize, press channel # to calibrate
- UC1 handheld display has similar interface for older testers

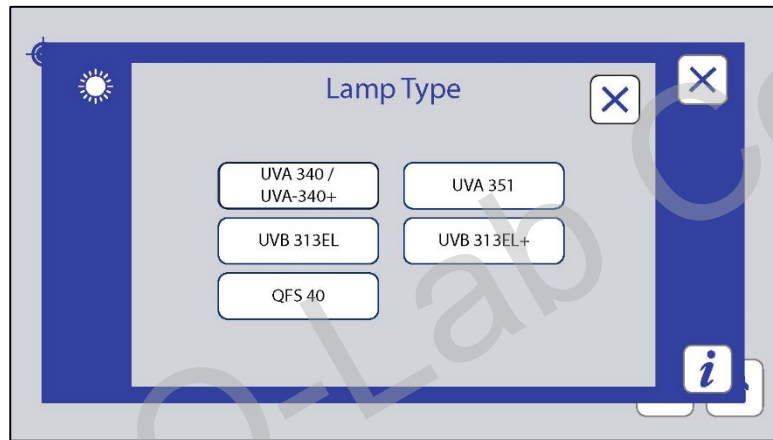

Lamp Selection

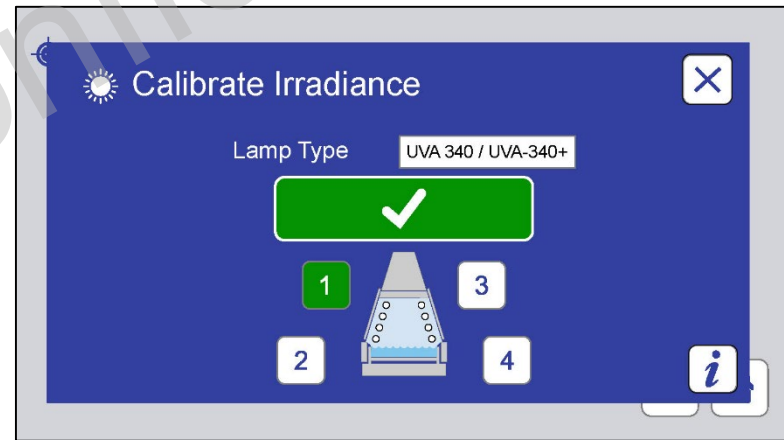

Lamp Channel Calibration

Panel Temperature Calibration

- Calibration required every 6 months
- QUV flashes a reminder when routine 6 month service is due
- Requires calibrated reference thermometer, insulated container, and hot/boiling water

Panel Temperature Calibration

Remove Sensor from Housing

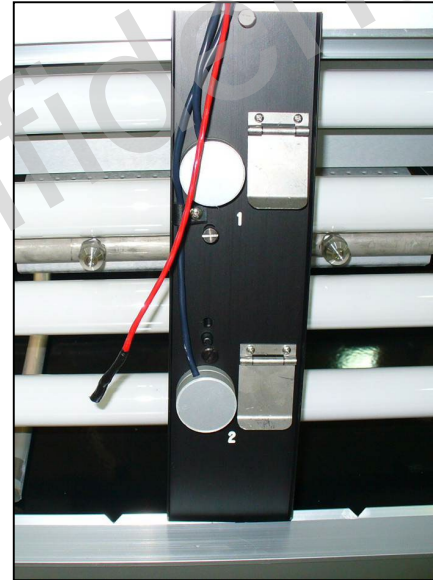
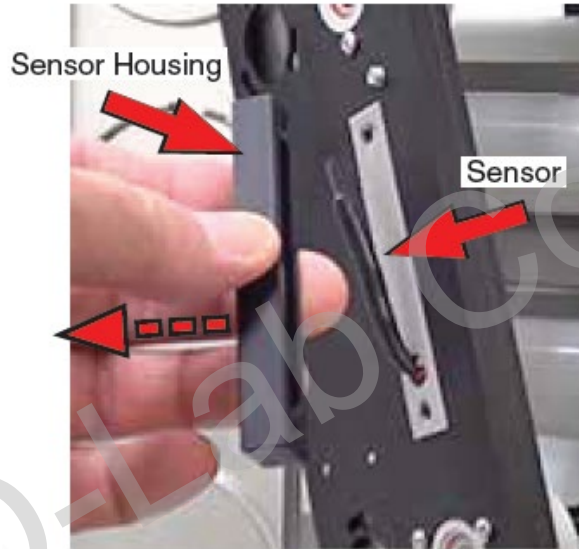

Panel Temperature Calibration

Attach QUV sensor to Reference Thermometer



Panel Temperature Calibration

Adjust Temperature

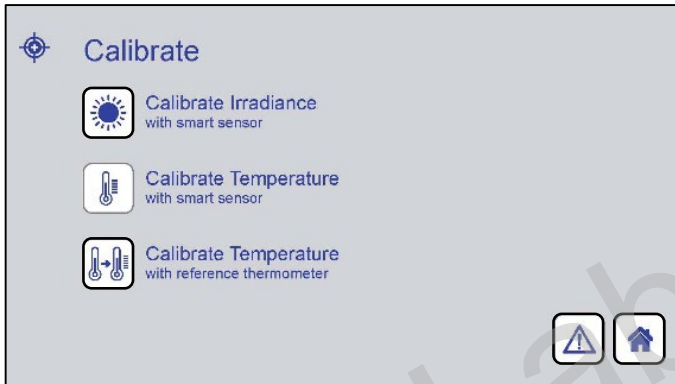

Calibration Menu



Read Reference Temperature

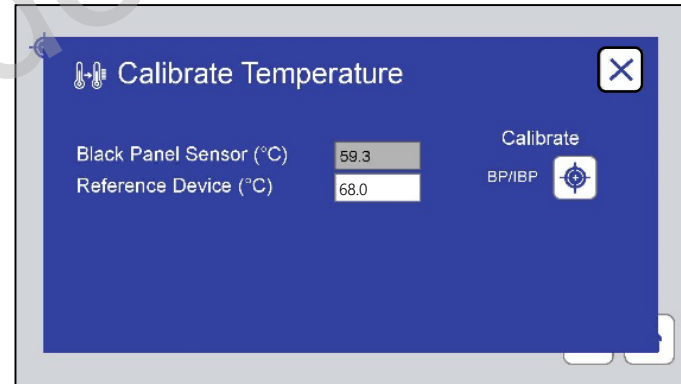

New Tester Sensor Temperature Adjustment

Topics

- Safety
- Functions of the Tester
- Running a Test
- Calibration
- **Maintenance**

Lamp Maintenance

- QUV/basic
 - Lamps need to be rotated every 400 light hours and two lamps replaced to maintain stability over a test
- QUV/se and QUV/spray
 - Spectrum does not shift, so change the lamps as needed to maintain irradiance
 - Lamps warranted up to:
 - 8,000 hours at Typical irradiance
 - 1,500 hours at High irradiance
 - 750 hours at Maximum irradiance

Water Pan Maintenance

- Clean water pan every 6 months
- If supplying tester with tap water, there can be significant mineral build-up, requiring more frequent cleaning
- More regular cleaning is recommended if specimens degrade and contaminate water

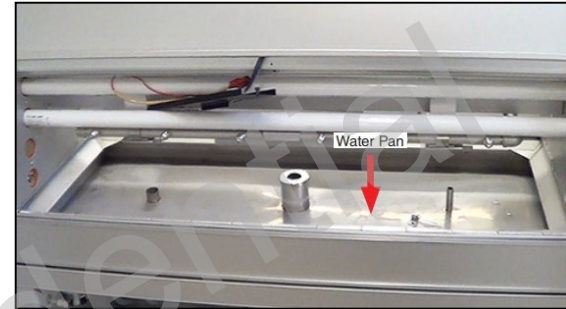

Clean QUV water pan



Significant mineral build-up

QUV/spray Maintenance

With inspection windows in place, check spray uniformity monthly

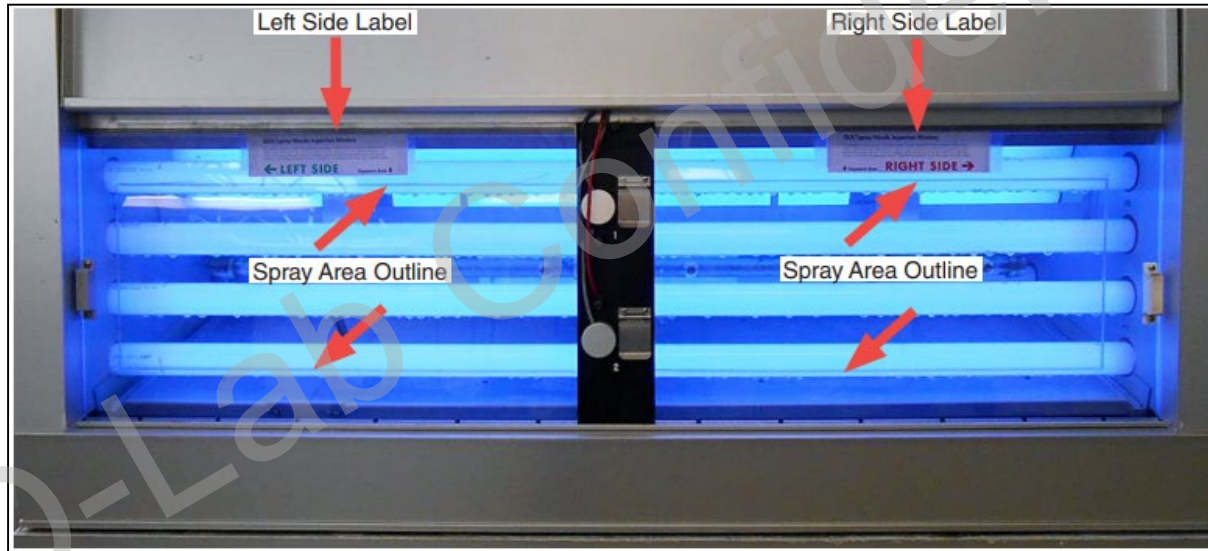

Water Filter Maintenance

- QUV/spray
 - Water Particulate Filter
 - Check every 6 months, replace annually or if dirty
- QUV/spray-RP
 - Repurification (Demineralizer) Cartridge
 - Replace if purity meter > 001
 - Carbon Filter & Particulate Filter
 - Check every 6 months, replace annually or if dirty
 - Reservoir
 - Clean periodically if dirty with mold

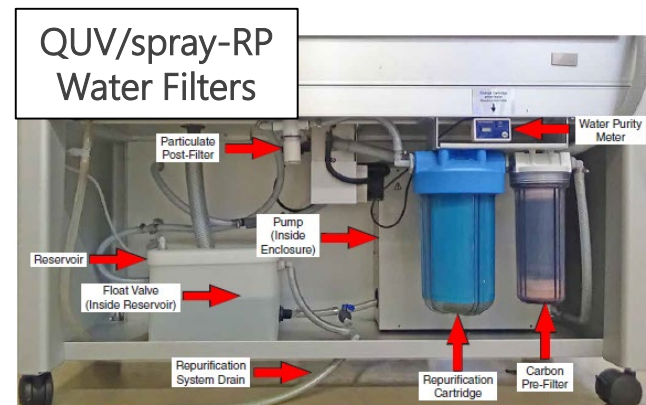
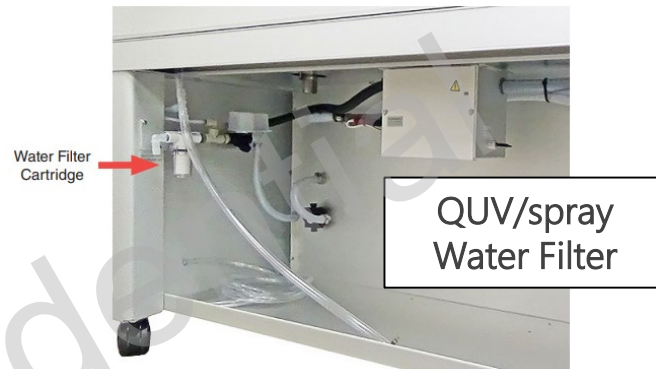

Field Calibration Audits, Tester Commissioning, and Customer Education

- This presentation was a condensed version of our QUV operator training. Typical training includes hands-on sessions and further in-depth review of tester components not covered here
- Q-Lab Repair team offers tester audits and field calibrations, in addition to their on-site repair visits and troubleshooting services.
- Q-Lab offers customized training plans that can be catered to each customer's demand and may include *Tester Commissioning* as well as *Weathering 101* and *Atmospheric Corrosion* education
- Contact info@q-lab.com or Repair@q-lab.com for more info

Thank you for your attention!

Questions?

Send your inquiry to:
info@q-lab.com